

INSTALLATION INSTRUCTIONS TO INSTALL PULL-DOWN KITCHEN FAUCETS

Thank you for purchasing this Wasserman® faucet. Anything missing or damaged, please do not return to the place you purchased. Call Toll Free at 1-866-670-6190 and we will send you replacements.

1. Turn off water at the supply valve under the sink or at the main water supply, disconnect the supply line, and remove old faucet.

Clean and dry surface area where new faucet will be mounted.

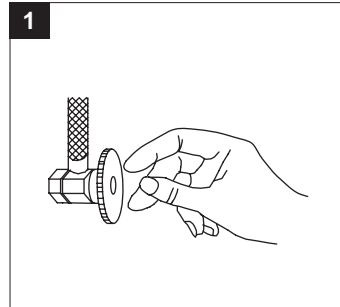

2. Position the faucet (A) on the sink surface (2.1).

Hand tighten the mounting nuts (B) to the faucet (A) tailpieces on the underside of the sink (2.1).

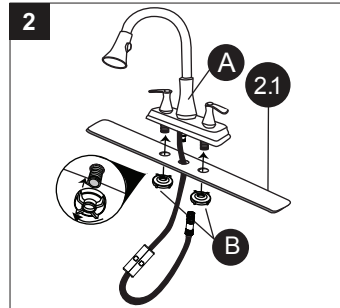

3. Plug the quick connector cover (3.3) into the faucet body adapter (3.2). Push all the way to the top. Pull down the hose (3.1) to lock quick connector. Check connection of the quick connector by pulling down the hose slightly.

Pull spray head in and out (3.4) to check for smooth operation.

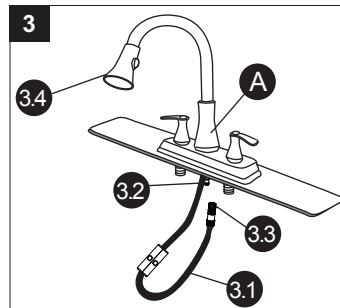

4. Connect the Water Supply Lines using a flexible braided supply line (4.1) (not included), connect the end with 1/2 in. female IPS to the tailpiece (4.2) of the faucet. Hand tighten. Do not overtighten. Install the other end of the supply line (4.1) to the shut-off valve or supply tube.

NOTE: Consumer should follow the directions on the supply line and if you have any questions about proper installation of the supply line, consult the manufacturer of the supply line.

NOTE: Do not use plumbers tape on connections, this will void the warranty. If the washer of the supply line is damaged, change to new one before install to the faucet.

DO NOT INSTALL SUPPLY LINE WITHOUT INSPECTION. Leakage will come from the supply line and possibly cause water damage to your house.

5. Turn water supply or shut-off valve back on and check for leaks. If leaks occur, tighten nuts slightly.

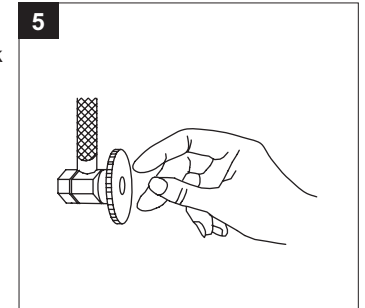
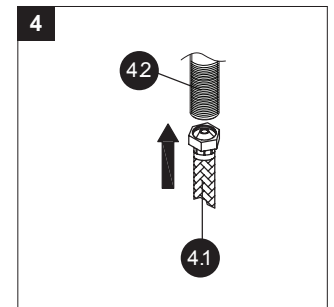

Limited Lifetime Warranty

This Wasserman® product is warranted to be free from defects in material or workmanship under normal use for the lifetime of the product. Any part of the product found to be defective during normal use will be replaced at our discretion. Warranty protects finish against tarnishing, flaking and discoloration. Warranty does not cover damage thorough accident, abuse, misuse, improper installation, etc. This warranty does not cover any losses, injuries or costs including indirect, incidental or consequential damages. This warranty covers the original purchaser only and may not be transferred or sold. When requesting warranty service please call toll-free 1-866-670-6190.